

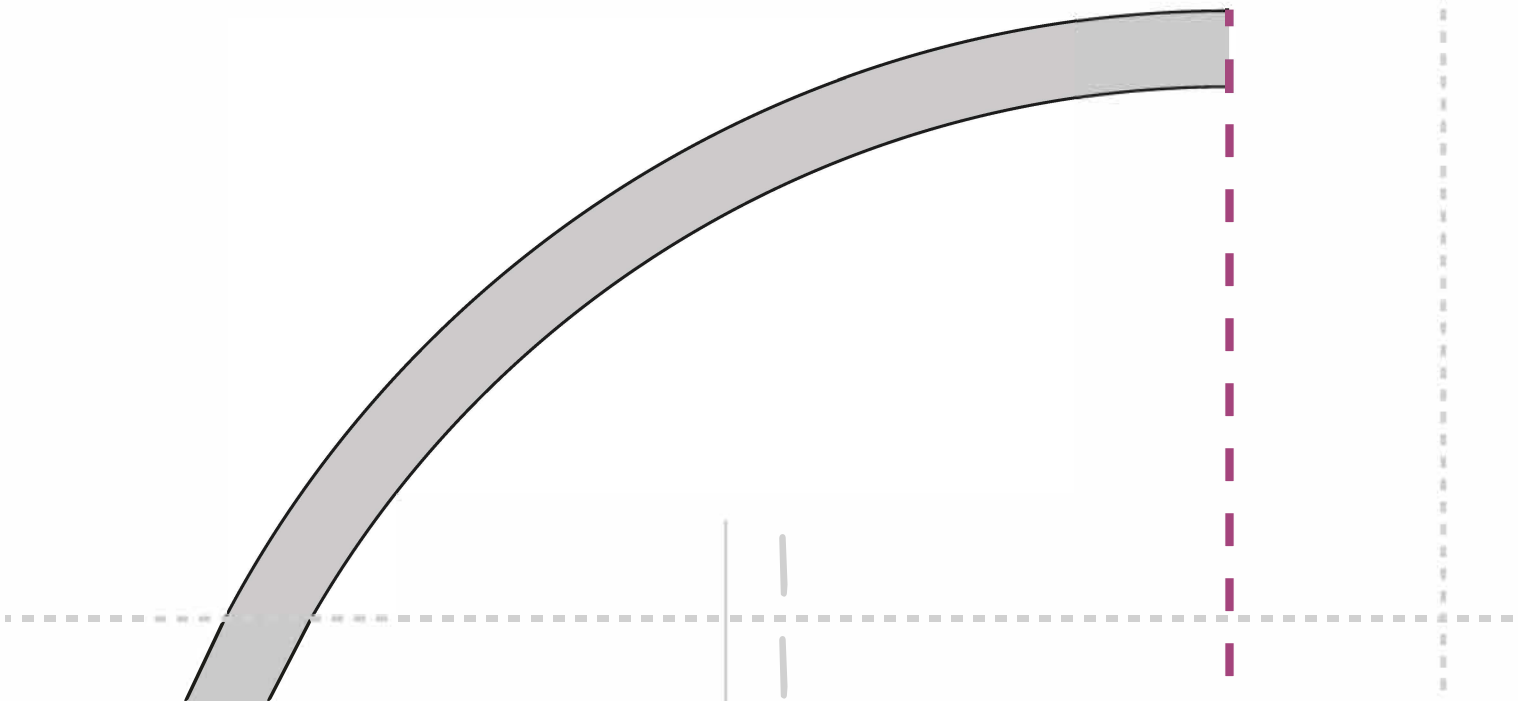

■ Prévoir 1 cm de marge de couture

# Patron pour coussin de yoga Freebie

a a



a a

Milieu

1x

22

22

En haut & en bas

2x

Pli

b

b

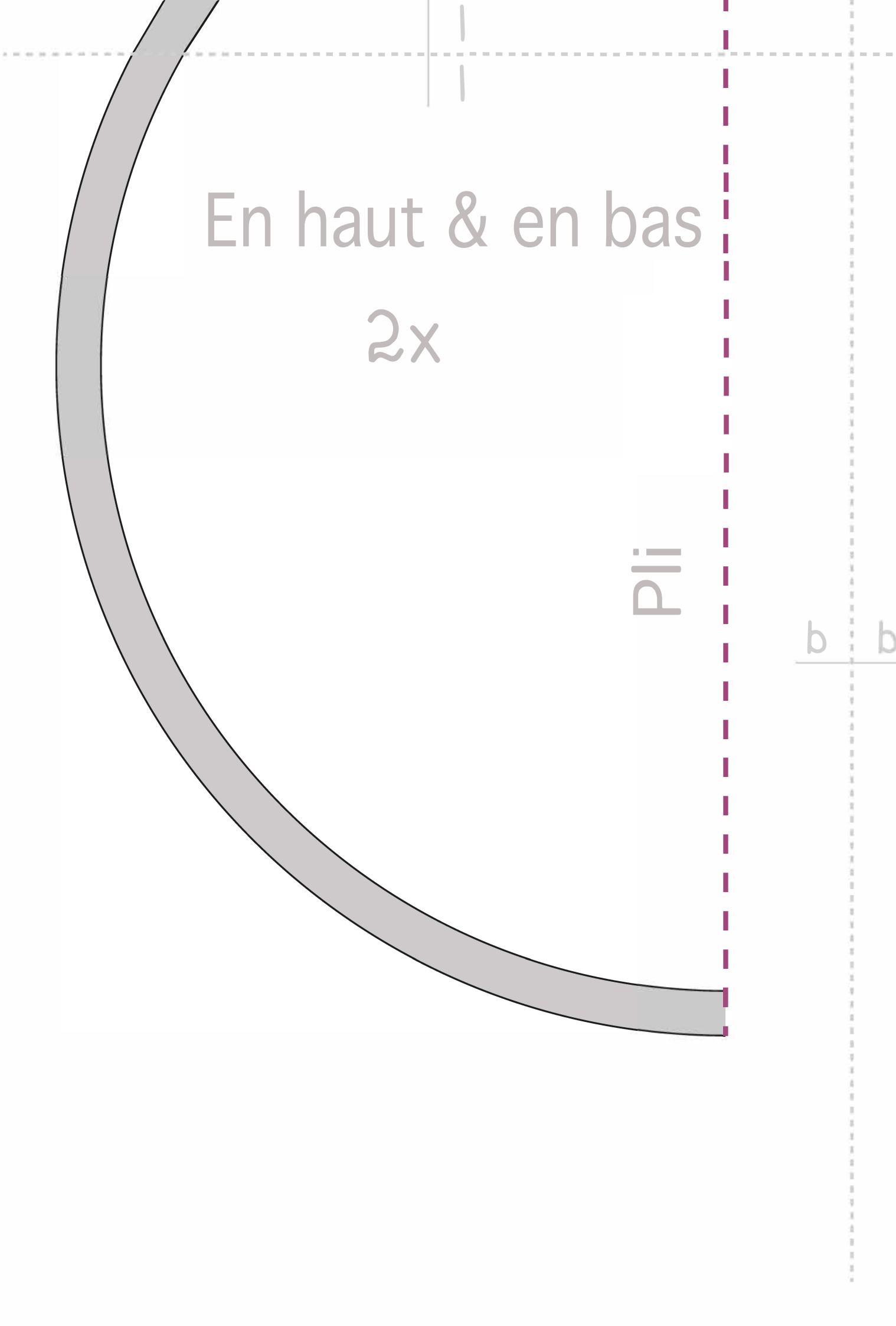

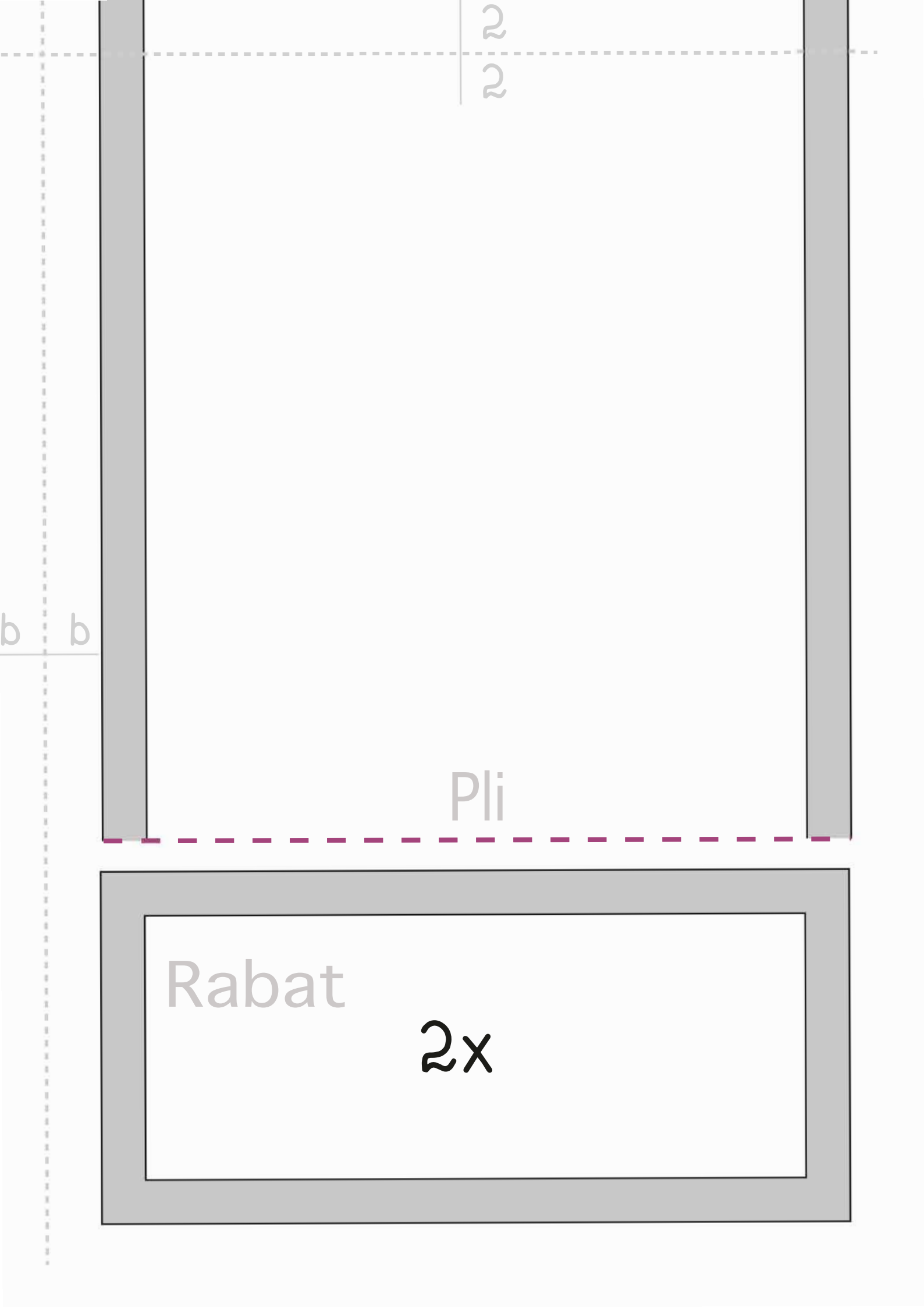

22

b b

Pli

Rabat

2x